

Section A-A

a. Single-Angle Die

Die Profile Dimensions, inch

Die Designation	A	B	C	R
Single Angle				
SA1	0.938	0.688	0.25	0.125
SA2	0.875	0.625	0.125	0.062
Compound Angle				
CA1	0.938	0.688	0.25	0.125
CA2	0.875	0.625	0.125	0.062

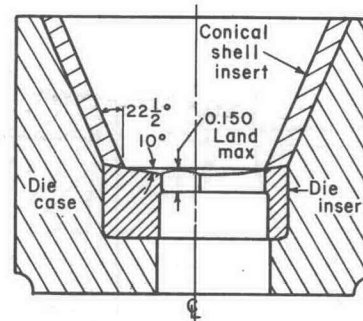

A-56539

b. Compound-Angle Die

Orifice Profile Dimensions Same as for Single-Angle Die

FIGURE 31. TWO DIE DESIGNS USED IN THE HYDROSTATIC EXTRUSION OF T-SECTIONS FROM ROUND BILLETS

All dimensions given in inches.

